

CODES:

FLORIDA BUILDING CODE 2014, 5TH EDITION
 ASCE STANDARD 7-2010
 MIAMI DADE WIND SPEED = 175 MPH

WIND DESIGN REQUIREMENTS:

ULTIMATE DESIGN WIND SPEED, Vult (3 sec. gust) 175 mph
 NOMINAL DESIGN WIND SPEED, Vasd 135 mph

RISK CATEGORY II
 HEIGHT TO CENTROID 15 FT max.
 EXPOSURE CATEGORY C
 ENCLOSURE CATEGORY N/A
 EFFECTIVE WIND AREA N/A

INTERNAL PRESSURE COEFFICIENT GCpI N/A
 DIRECTIONALITY FACTOR Kd 0.90
 TOPOGRAPHIC FACTOR Kzt 1.00
 GUST EFFECT FACTOR N/A

WIND LOAD METHOD:

VELOCITY PRESSURE:
 based on ASCE 7-10, Eq. 29.3-1
 $qz = 0.00256 Kz Kzt Kd V^2 \text{ psf}$
 $Kz = 0.85$
 $V = Vult$
 $qz = 60.0 \text{ psf}$

WIND PRESSURES:
 based on ASCE 7-10 Eq. 29.5.1 & FBC 1620.6
 $F = qh GCr Af \text{ psf}$ Eq. 29.5-2
 $GCr = 1.1 \text{ FOR LATERAL FORCES}$
 $GCr = 1.0 \text{ FOR VERTICAL FORCES}$

LOAD COMBINATIONS:

POSITIVE VERTICAL FORCE: $1.0 \cdot D + 0.6 \cdot W$ [FBC 1605.3.1 EQ. 16-12]
 SLIDING & ANCHOR PULLOUT: $0.6 \cdot D + 0.6 \cdot W$ [FBC 1605.3.1 EQ. 16-15]
 OVERTURNING: $0.67 \cdot D + 0.78 \cdot W$ [FBC 1605.3.2 EQ. 16-18]

GENERAL NOTES:

- THIS ENGINEERING REPORT DOCUMENTS THE ANALYSIS OF AC EQUIPMENT MOUNTED ON A CONCRETE FOUNDATION PAD AND THE ASSOCIATED ANCHORING SYSTEMS TO RESIST DEAD WEIGHT AND WIND LOAD FORCES.
- THE ANALYSIS CONFORMS TO THE REQUIREMENTS OF THE FLORIDA BUILDING CODE 2014 AND ASCE 7-2010, FOR USE WITHIN & OUTSIDE HVHZ.
- THE AC UNIT IS MOUNTED ON A CONCRETE FOUNDATION PAD. THE CONCRETE FOUNDATION PAD SHALL BE MIN 8" THICK AT ANCHOR LOCATIONS.
- THE ANCHORAGE IS DESIGNED AND VERIFIED BY STRUCTURAL ANALYSIS BY THIS ENGINEER.
- ALTERNATE DESIGNS FOR SUPPORTS WITHIN 15' OF GROUND LEVEL, THAT ARE DESIGNED TO RESIST THE ABOVE WIND LOADS MAY BE USED AT THE CONTRACTOR'S OPTION. FOR ALTERNATE DESIGNS FOR SUPPORTS WITHIN 15' OF GROUND LEVEL, PROVIDE DETAILS AND CALCULATIONS SIMILAR TO THIS SHEET AND DETAILED CALCULATIONS ON SHEET 2, STAMPED BY A PROFESSIONAL ENGINEER REGISTERED IN THE STATE OF FLORIDA.
- THE CONTRACTOR IS RESPONSIBLE FOR SAFETY, INSTALLATION, AND SPECIAL INSPECTIONS & TESTS PER FBC CHAPTER 17.

CALCULATIONS: SEE DETAILED CALCULATIONS ON SHEET 2.

WIND LATERAL AND VERTICAL FORCES:

- THE WIND LOAD ACTING NORMAL TO THE LARGE VERTICAL SIDE OF THE AC UNIT IS USED FOR WORST CASE SHEAR.
- THE WIND LOAD ACTING ON THE TOP OF THE UNIT UPWARD AND THE HORIZONTAL WIND LOAD ARE USED TO CALCULATE UPLIFT AND MOMENT.
- THESE FORCES MUST BE RESISTED BY THE SHEAR AND TENSILE STRENGTHS OF THE ANCHORS HOLDING THE UNIT TO THE CONCRETE FOUNDATION. THE ANCHORAGES & MOUNTING ARE VERIFIED BY THIS ENGINEER TO BE WITHIN THE ALLOWABLE STRENGTHS OF ITS ELEMENTS AND CONNECTIONS.

ENCLOSURE FASTENERS:

- THE METAL SHELL FASTENERS MUST RESIST THE NEGATIVE WIND PRESSURES CAUSING TENSILE STRESS IN THE SCREWS AND PULL-OVER EFFECTS OF THE SHEET METAL.

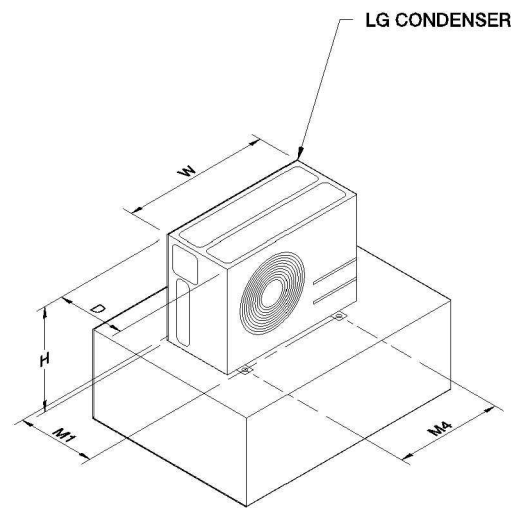

GROUND MOUNT CONFIGURATION

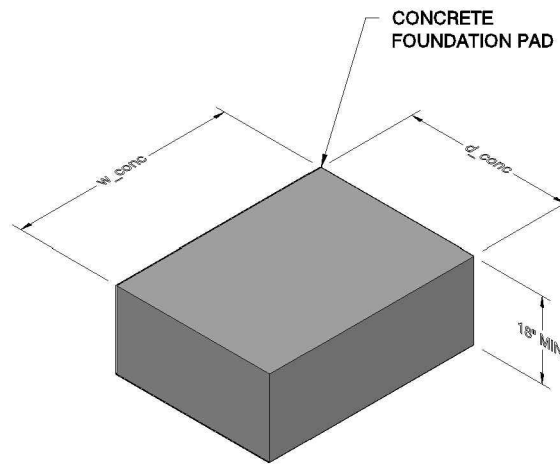

CONCRETE PAD W/ TURNDOWN EDGE

CONCRETE FOUNDATION PAD STRENGTH LIMITS		
LIMIT TYPE	AMOUNT	UNITS
MAX SHEAR AT ANCHOR	0.145	KIP
MAX PULLOUT AT ANCHOR	0.700	KIP

FOUNDATION NOTES:

- FOUNDATION IS DESIGNED AND VERIFIED FOR THE FORCES DESCRIBED IN THIS DOCUMENT AS SUMMARIZED IN THE ENGINEERING CALCULATIONS INCLUDED.
- t_{conc} = FOUNDATION SLAB THICKNESS = 8" MIN.
- FOUNDATION HEIGHT AT EDGES = 18" MIN.
- FOUNDATION SHALL EXTEND MIN. 12" BELOW GROUND.
- w_{conc} = FOUNDATION WIDTH = 50" MIN, 72" MAX.
- d_{conc} = FOUNDATION DEPTH = 44" MIN, 72" MAX.
- TOP OF FOUNDATION PAD SHALL BE MIN. 4" ABOVE ADJACENT GRADE.
- AC UNIT MUST BE CENTERED ON FOUNDATION.
- AC UNIT IS ANCHORED TO CONCRETE SLAB W/ GALV 1/4" Ø HILTI KWIK BOLT 3 ANCHORS WITH MIN. 2 1/2" EMBED. IN CONCRETE. EACH ANCHOR CAPACITY IS COMBINED TENSION = 700 LBS AND SHEAR = 145 LBS.
- MIN. REINFORCEMENT SHALL BE ONE LAYER OF #4 BARS @ 14" EACH WAY, CENTERED IN THE CONCRETE.
- FOUNDATION SUBGRADE SHALL BE COMPACTED TO PROVIDE MIN. 1200 PSF ALLOWABLE BEARING PRESSURE.

OTHER NOTES:

- 1"± NON-METALLIC NON-SHRINK GROUT MAY BE USED UNDER THE MOUNTING PLATES.

ENGINEERING CONFORMANCE ANALYSIS:

THE TABLE BELOW SHOWS DIMENSIONS, MIN FOUNDATION DEPTH & WIDTH, AND SHELL ENCLOSURE SCREWS FOR SOME MODELS OF LG ELECTRONICS USA HVAC OUTDOOR EQUIPMENT THAT MEET THE FOLLOWING ANALYSIS:

- FOUNDATION STRENGTH: STRENGTH TO RESIST UNIT WEIGHT AND WIND LOADS ON LATERAL AND VERTICAL SURFACES
- ANCHORS: PULLOUT AND SHEAR DUE TO OVERTURNING AND SLIDING FORCE IS WITHIN REQUIREMENTS
- EQUIPMENT METAL COVER FASTENERS: MIN NUMBER AND SIZE

MODELS: LMU3_CHV, LUU_7HV, LMU_0HV, ARUN0_GSS4		DESIGN CHECK W/ NOM/REQ'D ≥ 1.00 = OK											
MODEL #	CONDENSER DIMENSIONS						CONCRETE PAD		SHELL SCREWS		ANCHOR STRENGTH		METAL SHELL
	W	D	H	M1	M4	Wt	MIN d_conc	MIN w_conc	ON LONG SIDE, QTY. & SIZE	SHEAR	UPLIFT		
LMU30CHV	37.41	13.00	32.84	14.38	24.38	136.7	30	50	10,#10	0.58	0.38	0.20	
LMU36CHV	37.41	13.00	32.84	14.38	24.38	136.7	30	50	10,#10	0.58	0.38	0.20	
LMU187HV	37.41	13.00	32.84	14.38	24.38	132.3	30	50	10,#10	0.58	0.38	0.20	
LUU247HV	37.41	13.00	32.84	14.38	24.38	132.3	30	50	10,#10	0.58	0.38	0.20	
LMU480HV	37.41	13.00	54.34	14.38	24.38	213.8	30	50	10,#10	0.96	0.99	0.33	
LMU540HV	37.41	13.00	54.34	14.38	24.38	213.8	30	50	10,#10	0.96	0.99	0.33	
LMU600HV	37.41	13.00	54.34	14.38	24.38	213.8	30	50	10,#10	0.96	0.99	0.33	
LUU367HV	37.41	13.00	54.34	14.38	24.38	202.8	30	50	10,#10	0.96	0.99	0.33	
LUU427HV	37.41	13.00	54.34	14.38	24.38	202.8	30	50	10,#10	0.96	0.99	0.33	
ARUN038GSS4	37.41	13.00	54.34	14.38	24.38	207	30	50	10,#10	0.96	0.99	0.33	
ARUN048GSS4	37.41	13.00	54.34	14.38	24.38	207	30	50	10,#10	0.96	0.99	0.33	
ARUN054GSS4	37.41	13.00	54.34	14.38	24.38	207	30	50	10,#10	0.96	0.99	0.33	

NOTE: THE CONCRETE PAD DIMENSIONS ARE MINIMUMS. CONCRETE PAD MAY BE BUILT TO SUPPORT MORE THAN ONE CONDENSER UNIT AS OUTLINED IN THE LG ELECTRONICS USA INSTALLATION MANUAL.

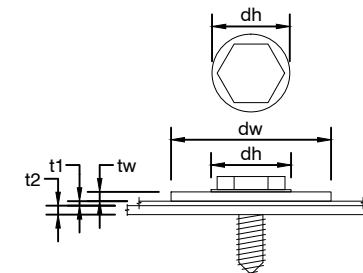

ENCLOSURE FASTENERS		
DESCRIPTION	SIZE	UNITS
SCREW SIZE (d)	#10	
INTEGRAL WASHER SIZE (dw)	0.50	IN
THICKNESS OF SHEET METAL (t1)	0.043	IN
MIN. THICKNESS OF FRAME (t2)	0.07	IN
DEPTH OF PENETRATION	0.25	IN
SCREW YIELD STRENGTH	55	KSI
ALLOWABLE TENSILE STRENGTH/SCREW	321	LBS
ALLOWABLE PULLOVER STRENGTH/SCREW	371	LBS
ALLOWABLE PULL-OUT STRENGTH/SCREW	170	LBS



your trusted advisor
engineers
consultants
architects
planners

11120 Kenwood Road
 Cincinnati, OH 45242
 p 513.791.1700 | f 513.791.1936
 www.ctconallians.com

State of Florida
 Certificate of Authorization
 # 31626

37-13-G-60 INFORMATION & DIAGRAMS
 LG ELECTRONICS USA HVAC
 OUTDOOR CONDENSING UNIT
 GROUND MOUNT CONFIGURATION

NO.	DATE	BY	DESCRIPTION

SCALE: NTS DATE: 10/28/16
 DRAWN BY: JDP PROJECT MGR: PCP
 PROJECT NO.: 160387 FLAT FILE:
 DRAWING NO.: 37-13-G-60
 SHEET 1 OF 2

ENGINEERING CALCULATION DETAIL SHEET

Outdoor Condensor Units on Concrete Pad - Suitability Verification
 Designed by: Paul C. Perrin, PE, SE

DESIGN METHODOLOGY: ASD

OBJECTIVE:
 Determine Wind Load on AC unit mounted on concrete foundation using ASCE 7 (2010), Section 29.5. Confirm stability, anchor configuration and strength, and equipment envelope fastening.

WIND LOAD: (See also "Wind Design Requirements" on Drawing 1)

Vult = 175 mph (FBC 2014 1620.2) for Miami-Dade, Risk Category II

From "29.3 Velocity Pressure"
 $qz = 0.00256 * Kz * Kzt * Kd * V^2 = 60.0 \text{ psf}$ (Eq. 29.3-1)

From "29.5 Design Wind Loads - Other Structures"
 $F = qz(GCr)Af$ (Eq. 29.5-1)

Fvertical = 60.0 psf * (1.0) * Af = 60.0 psf x Area (ft^2)
 Flateral = 60.0 psf * (1.1) * Af = 66.0 psf x Area (ft^2)

Example AC Unit:

Use LUU187HV in Table w/ dims (W, D, H, Wt) = (37.41", 13.0", 32.84", 132.3 lbs)

WIND LOAD FORCES:

Top Area = 13.0" * 37.41" / (144 in^2/ft^2) = 3.38 sf
 Fw vertical (Fw_vert) = 60.0 psf * 3.38 sf = 203 lbs (unfactored)

Long side Area = 37.41" * 32.84" / (144 in^2/ft^2) = 8.53 sf
 Fw lateral (Fw_lat) = 66.0 psf * 8.53 sf = 563 lbs (unfactored)

LOAD COMBINATIONS:

0.67D + 0.78W for overturning FBC 1605.3.2 Eq. 16-18
 0.6D + 0.6W for sliding and anchors FBC 1605.3.1 Eq. 16-15

CALCULATE REACTION FORCES ON CONCRETE FOUNDATION:

Shear V1 = 0.6 * Fw_lat / 4 anchors = 0.6 * 563 # / 4 = 84 lbs
 Pull-up R1 = [0.78 * Fw_lat * H/2 + (0.78 * Fw_vert - 0.67 * Wt) * (M1/2)] / (M1/2) / 2 legs
 = [0.78 * 563 # * (32.84"/2) + (0.78 * 203 # - 0.67 * 132.3 #) * (14.375"/2)] / (14.375"/2)
 = 0.268 kips

SOIL BEARING PRESSURE AT CONCRETE FOUNDATION:

Wt conc = 150 pcf * {t_conc * w_conc * d_conc + (18" - t_conc) * 2 * t_conc * [w_conc + (d_conc - 2 * t_conc)]}
 = 150 pcf * {8" * 50" * 44" + (18" - 8") * 2 * 8" * [50" + (44" - 2 * 8")]}
 = 2.61 kips

P = 0.67 * (Wt + Wt_conc) - 0.78 * Fw_vert
 = 0.67 * (0.132 kip + 2.61 kip) - 0.78 * 203 #
 = 1.680 kip

M_ot = 0.78 * Fw_lat * (18" + H/2)
 = 0.78 * 563 # * (18" + 32.84"/2)
 = 15.111 kip*in

e = M_ot / P = 15.111 kip*in / 1.680 kips = 8.99"

If e = 8.99" > d_conc/6 = 7.33"
 then Pmax = 2P / {3 * w_conc * [(d_conc/2) - e]}
 = 2 * 1.680 kip / {3 * 50" * [(44"/2) - 8.99"]}
 = 248 psf

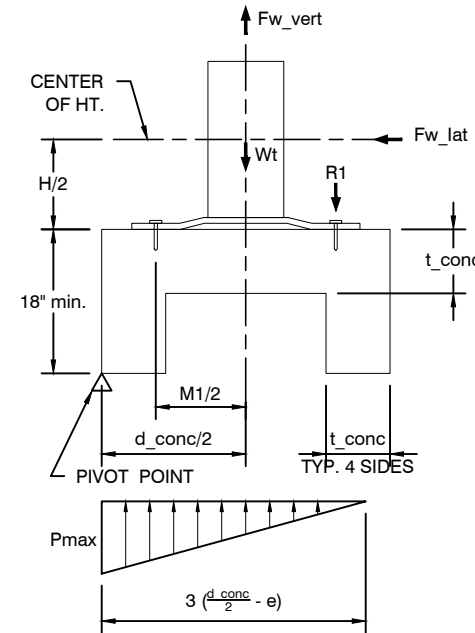

DESIGN METHODOLOGY: ASD

VERIFY ANCHOR SHEAR RESISTANCE TO SLIDING:

Use Load Combination FBC 1605.3.1 Eq. 16-15
 $0.6D + 0.6W = 0.6 * Fw_lat = 0.6 * 563 \# = 338 \text{ lbs}$
 Shear per anchor = 338# / 4 = 84 lbs
 Fsliding nominal = 0.145 kips
 Since 0.145 kips > 0.084 kips

Resistance to Sliding Checks OK.

CHECK OVERTURNING ANCHOR PULLOUT/UPLIFT RESISTANCE:

Use Load Combination FBC 1605.3.1 Eq. 16-15
 $0.6D + 0.6W$
 On one anchor
 Pull-up R1 = 0.268 kips
 Max uplift at one anchor = 0.700 kips
 Since 0.700 kips > 0.268 kips

Anchor Resistance to Overturning Checks OK.

CHECK SHEET METAL ENVELOPE FASTENER RESISTANCE:

Analysis based on AISI S100-2007 "Cold Formed Steel Structural Members" Section E4: Screw Connections
 Use Load Combination FBC 1605.3.1 Eq. 16-15
 $0.6D + 0.6W$
 On long side worst case
 $0.60 * Fw_lat = 0.60 * 563 \# = 338 \text{ lbs}$

Resistance to the metal shell pull-off is the minimum of the tensile strength of the screw and the pull-over strength of the sheet metal.

Inputs:

#10 screw, d = 0.19" with integral 0.5"-diameter washer
 Thickness of metal shell, t1 = 0.043" (18 gauge)
 Depth of penetration of screw into frame, tc = 0.25"
 Strength of screw, Fu1 = 55 ksi

Based on the above data:

Allowable tensile of the screw, Pts/Omega = 321 lbs per screw (where Omega = 3.0)
 Allowable Pull-out strength, Pnot/Omega = 170 lbs per screw
 Allowable Pull-over strength, Pnov/Omega = 371 lbs per screw
 Therefore the min number of screws per long side = 338# / 170#/screw = 1.99 screws
 Rounds up to min 2 screws per side, use 10 screws, spaced evenly.

Anchor Resistance to Metal Enclosure Pull-Off Checks OK.

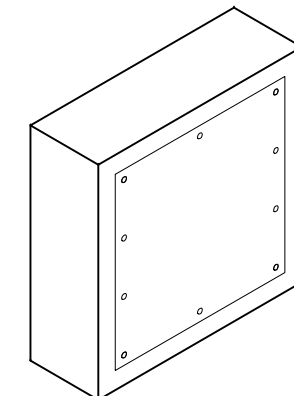

SCREW PATTERN

SCALE: NTS

THE CALCULATIONS ON THE DRAWING ARE REPRESENTATIVE OF THE FOLLOWING LG ELECTRONICS OUTDOOR CONDENSING UNITS:

LMU30CHV
LMU36CHV
LUU187HV
LUU247HV
LMU480HV
LMU540HV
LMU600HV
LUU367HV
LUU427HV
ARUN038GSS4
ARUN048GSS4
ARUN054GSS4

37-13-G-60 CALCULATIONS

LG ELECTRONICS USA HVAC
 OUTDOOR CONDENSING UNIT
 GROUND MOUNT CONFIGURATION

your trusted advisor
consultants
 engineers
 architects
 planners

1120 Kenwood Road
 Cincinnati, OH 45242
 p 513.791.1700 f 513.791.1936
 www.cticonsultants.com

State of Florida
 Certificate of Authorization
 # 31626



REVISIONS	
NO.	DESCRIPTION

SCALE	DATE
NTS	10/28/16
DRAWN BY	PROJECT MGR
JDP	PCP
PROJECT NO.	FLAT FILE
160387	
DRAWING NO.	
37-13-G-60	
SHEET 2 OF 2	

11/10/2016 2:48 PM Benjamin Sugawara
 H:\2016\160387\DWG\Sheets\37-13-G-60.dwg Tab: 37-13-G-60-2