

CODES:

FLORIDA BUILDING CODE 2014, 5TH EDITION
ASCE STANDARD 7-2010
MIAMI DADE WIND SPEED = 186 MPH

WIND DESIGN REQUIREMENTS:

ULTIMATE DESIGN WIND SPEED, V_{ult} (3 sec. gust) 186 mph
NOMINAL DESIGN WIND SPEED, V_{asd} 144 mph

RISK CATEGORY IV
HEIGHT TO CENTROID 77 FT
EXPOSURE CATEGORY D
ENCLOSURE CATEGORY N/A
EFFECTIVE WIND AREA N/A

INTERNAL PRESSURE COEFFICIENT GCP_i N/A
DIRECTIONALITY FACTOR K_d 0.9
TOPOGRAPHIC FACTOR K_{zt} 1.0
GUST EFFECT FACTOR N/A

WIND LOAD METHOD:

VELOCITY PRESSURE:
based on ASCE 7-10, Eq. 29.3-1
 $q_z = 0.00256 K_z K_{zt} K_d V^2$ psf
 $K_z = 1.37$
 $V = V_{ult}$
 $q_z = 109.2$ psf

WIND PRESSURES:

based on ASCE 7-10 Eq. 29.5.1 & FBC 1620.6
 $F = q_h G_C f A_f$ psf Eq. 29.5-2
 $G_C f = 3.10$ FOR LATERAL FORCES
 $G_C f = 1.50$ FOR VERTICAL FORCES

LOAD COMBINATIONS:

POSITIVE VERTICAL FORCE: $1.0 \cdot D + 0.6 \cdot W$ [FBC 1605.3.1 EQ. 16-12]
SLIDING & ANCHOR PULLOUT: $0.6 \cdot D + 0.6 \cdot W$ [FBC 1605.3.1 EQ. 16-15]
OVERTURNING: $0.67 \cdot D + 0.78 \cdot W$ [FBC 1605.3.2 EQ. 16-18]

GENERAL NOTES:

1. THIS ENGINEERING REPORT DOCUMENTS THE ANALYSIS OF AC EQUIPMENT MOUNTED ON A ROOF STAND AND THE ASSOCIATED ANCHORING SYSTEMS TO RESIST DEAD WEIGHT AND WIND LOAD FORCES.
2. THE ANALYSIS CONFORMS TO THE REQUIREMENTS OF THE FLORIDA BUILDING CODE 2014 AND ASCE 7-2010, FOR USE WITHIN & OUTSIDE HVHZ.
3. THE AC UNIT IS MOUNTED ON A METAL STAND WHICH IS SECURED TO THE ROOF.
4. ANCHORS USED TO FASTEN THE UNIT TO THE ROOF STAND ARE A307 OR HIGHER STRENGTH STEEL BOLTS.
5. THE ROOF STAND IS DESIGNED AND VERIFIED BY STRUCTURAL ANALYSIS BY THIS ENGINEER.
6. ALTERNATE ROOF STAND DESIGNS (E.G. ALUMINUM) THAT ARE DESIGNED TO RESIST THE ABOVE WIND LOADS MAY BE USED AT THE CONTRACTOR'S OPTION. FOR ALTERNATE ROOF STAND DESIGNS, PROVIDE DETAILS AND CALCULATIONS SIMILAR TO THIS SHEET AND DETAILED CALCULATIONS ON DRAWING 2, STAMPED BY A PROFESSIONAL ENGINEER REGISTERED IN THE STATE OF FLORIDA.
7. THE CONTRACTOR IS RESPONSIBLE FOR SAFETY, INSTALLATION, AND SPECIAL INSPECTIONS & TESTS PER FBC CHAPTER 17.

CALCULATIONS: SEE DETAILED CALCULATIONS ON DRAWING 2.

WIND LATERAL AND VERTICAL FORCES:

1. THE WIND LOAD ACTING NORMAL TO THE LARGE VERTICAL SIDE OF THE AC UNIT IS USED FOR WORST CASE SHEAR.
2. THE WIND LOAD ACTING ON THE TOP OF THE UNIT UPWARD AND THE HORIZONTAL WIND LOAD IS USED TO CALCULATE UPLIFT AND MOMENT.
3. THESE FORCES MUST BE RESISTED BY THE SHEAR AND TENSILE STRENGTHS OF THE ANCHORS HOLDING THE UNIT TO THE SUPPORT BAR AND ALSO THE ANCHORS HOLDING THE SUPPORT BAR TO THE ROOF STAND. THE ROOF STAND INTERNAL STRESSES ARE VERIFIED BY THIS ENGINEER TO BE WITHIN THE ALLOWABLE STRENGTHS OF ITS ELEMENTS AND CONNECTIONS.

SUPPORT BAR STRENGTH:

4. THE MOMENT AND SHEAR MUST BE TRANSFERRED FROM THE AC UNIT TO THE ROOF STAND BY A SUPPORT BAR AS THE AC UNIT DEPTH CAN BE UNEQUAL TO THE ROOF STAND DEPTH.
5. MAX MOMENT AND SHEAR TO THE SUPPORT BAR DETERMINE SELECTION OF THE SUPPORT BAR.

ROOF STAND STRENGTH:

6. CRITICAL LIMITS ARE THE POST LEGS AND WELD STRENGTH TO THE BASE, CROSS BRACE TO POST CONNECTION, AND RAILING TO POST CONNECTION.

ENCLOSURE FASTENERS:

7. THE METAL SHELL FASTENERS MUST RESIST THE NEGATIVE WIND PRESSURES CAUSING TENSILE STRESS IN THE SCREWS AND PULL-OVER EFFECTS OF THE SHEET METAL.

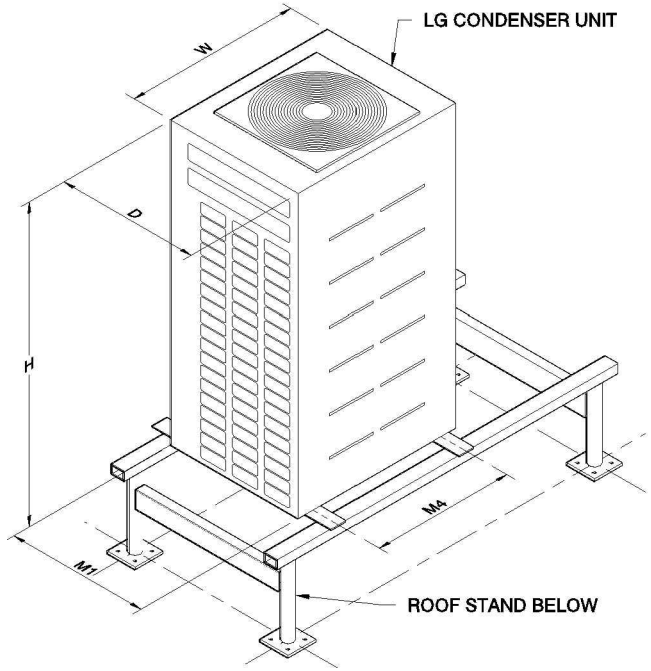

ROOF-MOUNT CONFIGURATION

SCALE: NTS

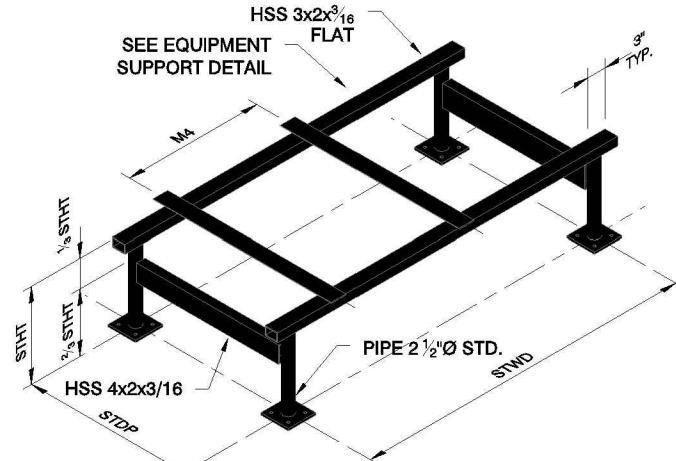

STEEL ROOF STAND

SCALE: NTS

ROOF STAND STRENGTH LIMITS		
LIMIT TYPE	AMOUNT	UNITS
MAX SHEAR AT POST BASE	1.050	KIP
MAX PULLOUT AT POST BASE	2.750	KIP
MAX MOMENT AT POST BASE	17.20	KIP*IN
MAX MOMENT AT CROSS BRACE	21.17	KIP*IN

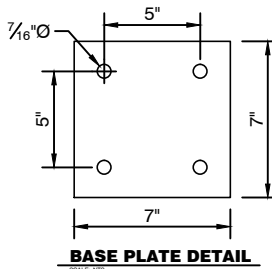

BASE PLATE DETAIL

ROOF STAND NOTES:

1. ROOF STAND IS DESIGNED AND VERIFIED FOR THE FORCES DESCRIBED IN THIS DOCUMENT AS SUMMARIZED IN THE ENGINEERING CALCULATIONS INCLUDED.
2. STHT = STAND HEIGHT = MIN 18", MAX 30".
3. STWD = STAND POST SPACING = 42" MIN, 48" MAX.
4. STDP = STAND DEPTH = 40" MIN, 48" MAX.
5. EQUIPMENT SUPPORT AND FASTENERS TO STAND TOP RAIL ARE DEFINED IN SEPARATE DETAIL.
6. AC UNIT MUST BE CENTERED ON SUPPORT.
7. 1/2" BASE PLATE IS ANCHORED TO CONCRETE SLAB W/ 3/8" Ø ADHESIVE ANCHORS (HILTI HIT-HY 200+HAS) WITH MIN. 3 3/8" EMBED. OF GALV HAS RODS IN CONCRETE. ANCHOR GROUP CAPACITY COMBINED TENSION = 2750 LBS, SHEAR = 1050 LBS, AND MOMENT 17200 IN*LBS.
8. IF NO ROOF SLAB, BASE PLATES SHALL BE ANCHORED TO STEEL ROOF FRAMING (DESIGNED BY OTHERS FOR THESE LOADS) WITH 3/8" Ø A307 BOLTS.

STEEL FABRICATION NOTES:

- ALL MATERIAL IS STEEL WITH MIN $F_y = 35$ KSI.
- ALL JOINTS SHALL BE WELDED CONTINUOUS ALL AROUND W/ 3/16" FILLET.

OTHER NOTES:

- EQUIPMENT SUPPORT IS NOT PART OF ROOF STAND.
- MIN NUMBER OF POSTS IS 4 PER CONDENSER. FOR MULTIPLE CONDENSERS, USE ONE STAND PER CONDENSER.
- 1" ± NON-METALLIC NON-SHRINK GROUT MAY BE USED UNDER THE BASE PLATES.

ENGINEERING CONFORMANCE ANALYSIS:

THE TABLE BELOW SHOWS DIMENSIONS, MIN STAND DEPTH, AND SHELL ENCLOSURE SCREWS FOR SOME MODELS OF LG ELECTRONICS USA HVAC OUTDOOR EQUIPMENT THAT MEET THE FOLLOWING ANALYSIS:

- ROOF STAND STRENGTH: POST AND CROSS-BRACE STRENGTH TO RESIST UNIT WEIGHT AND WIND LOAD LATERAL AND VERTICAL SURFACES
- STAND POST ANCHORS: PULLOUT AND SHEAR DUE TO OVERTURNING AND SLIDING FORCE IS WITHIN REQUIREMENTS
- EQUIPMENT METAL COVER FASTENERS: MIN NUMBER AND SIZE

MODEL #	CONDENSER DIMENSIONS						ROOF STAND DIMS: STDP MIN (IN)	SHELL SCREWS ON LONG SIDE, QTY. & SIZE	DESIGN CHECK W/ NOM/REQ'D ≥ 1.00 = OK				
	W	D	H	M1	M4	Wt			ANCHOR SHEAR	UPLIFT	STAND STRENGTH		METAL SHELL
											BRACE MOMENT		
ARUB072BTE4	36.25	29.94	66.13	29.06	31.19	442	40	22, #10	0.81	0.95	0.80	0.91	
ARUB072DTE4	36.25	29.94	66.13	29.06	31.19	442	40	22, #10	0.81	0.95	0.80	0.91	
ARUN072BTE4	36.25	29.94	66.13	29.06	31.19	442	40	22, #10	0.81	0.95	0.80	0.91	
ARUN072DTE4	36.25	29.94	66.13	29.06	31.19	442	40	22, #10	0.81	0.95	0.80	0.91	
ARUB072BTE5	36.25	29.94	66.13	29.06	31.19	442	40	22, #10	0.81	0.95	0.80	0.91	
ARUB072DTE5	36.25	29.94	66.13	29.06	31.19	442	40	22, #10	0.81	0.95	0.80	0.91	

NOTE: STAND DIMENSIONS ARE MINIMUMS. STAND SHALL BE BUILT TO SUPPORT ONE CONDENSER UNIT AS OUTLINED IN THE LG ELECTRONICS USA INSTALLATION MANUAL.

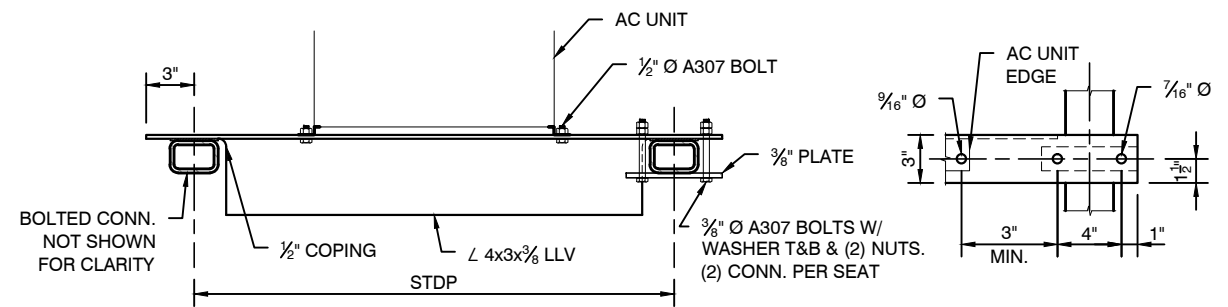

EQUIPMENT SUPPORT DETAIL

SCALE: NTS

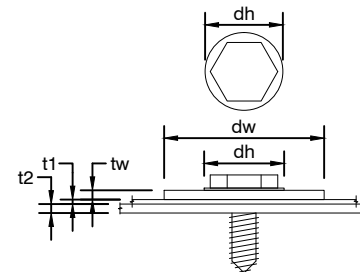

ENCLOSURE FASTENERS		
DESCRIPTION	SIZE	UNITS
SCREW SIZE (d)	#10	
INTEGRAL WASHER SIZE (dw)	0.50	IN
THICKNESS OF SHEET METAL (t1)	0.043	IN
MIN. THICKNESS OF FRAME (t2)	0.07	IN
DEPTH OF PENETRATION	0.25	IN
SCREW YIELD STRENGTH	55	KSI
ALLOWABLE TENSILE STRENGTH/SCREW	321	LBS
ALLOWABLE PULLOVER STRENGTH/SCREW	371	LBS
ALLOWABLE PULL-OUT STRENGTH/SCREW	170	LBS



your trusted advisor
engineers
consultants
architects
planners

11120 Kenwood Road
Cincinnati, OH 45242
p 513.791.1700 | f 513.791.1936
www.cticonsultants.com

State of Florida
Certificate of Authorization
31626

DRAWING TITLE: 36-30-R-109 INFORMATION & DIAGRAMS
PROJECT TITLE: LG ELECTRONICS USA HVAC OUTDOOR CONDENSING UNIT ROOF MOUNT CONFIGURATION

NO.	DATE	BY	DESCRIPTION

SCALE: NTS

DRAWN BY: JDP

PROJECT NO: 160387

DATE: 11/02/16

PROJECT MGR: PCP

FLAT FILE

DRAWING NO. 36-30-R-109

SHEET 1 OF 2

ENGINEERING CALCULATION DETAIL SHEET

Outdoor Condensor Units on Roof Stand - Suitability Verification
 Designed by: Paul C. Perrin, PE, SE

DESIGN METHODOLOGY: ASD

OBJECTIVE:

Determine Wind Load on AC unit mounted on roof stand using ASCE 7 (2010), Section 29.5. Confirm stability, roof stand strength, anchor configuration and strength, and equipment envelope fastening.

WIND LOAD: (See also "Wind Design Requirements" on Drawing 1)

Vult = 186 mph (FBC 2014 1620.2) for Miami-Dade, Risk Category IV

From "29.3 Velocity Pressure"
 $qz = 0.00256 \cdot Kz \cdot Kzt \cdot Kd \cdot V^2 = 109.2 \text{ psf}$ (Eq. 29.3-1)
 From "29.5 Design Wind Loads - Other Structures"
 $F = qz \cdot (GCr) \cdot Af$ (Eq. 29.5-1)

Fvertical = $109.2 \text{ psf} \cdot (1.50) \cdot Af = 163.8 \text{ psf} \cdot \text{Area (ft}^2)$
 Flateral = $109.2 \text{ psf} \cdot (3.10) \cdot Af = 338.5 \text{ psf} \cdot \text{Area (ft}^2)$

Example AC Unit:

Use LSU090HEV1 in Table w/ dims (W, D, H, Wt) = (36.25", 29.94", 66.13", 442 lbs)

WIND LOAD FORCES:

Top Area = $29.94" \cdot 36.25" / (144 \text{ in}^2/\text{ft}^2) = 7.54 \text{ sf}$
 Fw vertical (Fw_vert) = $163.8 \text{ psf} \cdot 7.54 \text{ sf} = 1235 \text{ lbs}$ (unfactored)

Long side Area = $36.25" \cdot 66.13" / (144 \text{ in}^2/\text{ft}^2) = 16.65 \text{ sf}$
 Fw lateral (Fw_lat) = $338.5 \text{ psf} \cdot 16.65 \text{ sf} = 5636 \text{ lbs}$ (unfactored)

LOAD COMBINATIONS:

0.67D + 0.78W for overturning FBC 1605.3.2 Eq. 16-18
 0.6D + 0.6W for sliding and anchors FBC 1605.3.1 Eq. 16-15

CALCULATE REACTION FORCES ON ROOF STAND:

Shear V1 = $0.6 \cdot Fw_lat / 4 \text{ posts} = 0.6 \cdot 5636 \# / 4 = 845 \text{ lbs}$
 Pull-up R1 = $[0.6 \cdot Fw_lat \cdot b + (0.6 \cdot Fw_vert - 0.6 \cdot Wt) \cdot (a+3")] / (2 \cdot a+3") / 2 \text{ posts}$
 $= [0.6 \cdot 5636 \# \cdot (30" + 66.13"/2) + (0.6 \cdot 1235 \# - 0.6 \cdot 442 \#) \cdot (20"/2 + 3")] / (20" + 3") / 2$
 $= 2.607 \text{ kips}$
 Moment MB = $V1 \cdot ST-U = 845 \# \cdot ST-U = 16.907 \text{ kip} \cdot \text{in}$

NOMINAL STRENGTH OF ROOF STAND:

All limits are based on posts at min. depth of 40", max. height of 30", and max. spacing of 48".
 Limits: Shear at base, Uplift at one post, Moment on frame
 Given:

- (4) anchors per base with allowable max pull-up of 2750 lbs, allowable max shear of 1050 lbs and allowable max moment of 17,200 kip*in per anchor group, (3/8" diameter adhesive anchor with 3.375" embedment in min 3000 psi concrete).
- All welds 3/16" fillet. All materials steel with min Fy = 35 ksi.

Posts are 2.5" Ø standard pipe.

Cross brace is HSS 4 x 2 x 3/8

Limits per post:

Max shear = min(pipe shear, anchor shear)
 $= \min(0.6 \cdot 35 \text{ ksi} \cdot 1.61 \text{ in}^2 / 1.67, 1.050 \text{ kips})$
 $= 1.050 \text{ kips}$

Max uplift at one post = anchor pull-up capacity = 2750 lbs = 2.750 kips

Max moment at brace
 $= \min(\text{brace flexural strength, weld strength, post flexural strength})$
 $= \min(46 \text{ ksi} \cdot 1.83 \text{ in}^3 / 1.67, 2.78 \text{ kip/in} \cdot 2" \cdot 4", 35 \text{ ksi} \cdot 1.01 \text{ in}^3 / 1.67)$
 $= \min(50.4 \text{ kip} \cdot \text{in}, 22.3 \text{ kip} \cdot \text{in}, 21.2 \text{ kip} \cdot \text{in})$
 $= 21.2 \text{ kip} \cdot \text{in}$

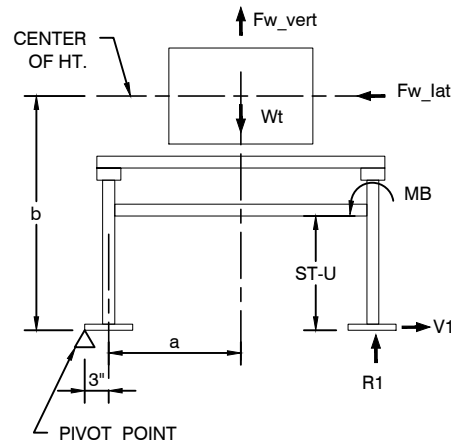

SINCE THIS DESIGN IS BASED ON WIND PRESSURE, qz, THIS DESIGN IS ALSO SUITABLE FOR THE FOLLOWING CASES:

- MIAMI DADE WIND SPEED = 186 MPH, RISK CATEGORY IV, EXPOSURE CATEGORY C, HEIGHT UP TO 146 FT.
- MIAMI DADE WIND SPEED = 186 MPH, RISK CATEGORY II, EXPOSURE CATEGORY D, HEIGHT UP TO 160 FT.
- BROWARD WIND SPEED = 180 MPH, RISK CATEGORY IV, EXPOSURE CATEGORY D, HEIGHT UP TO 116 FT.

DESIGN METHODOLOGY: ASD

VERIFY ANCHOR SHEAR RESISTANCE TO SLIDING:

Use Load Combination FBC 1605.3.1 Eq. 16-15
 $0.6D + 0.6W = 0.6 \cdot Fw_lat = 0.6 \cdot 5636 \# = 3382 \text{ lbs}$
 Shear per post = $3382 \# / 4 = 845 \text{ lbs}$
 Fsliding nominal resistance = 1.050 kips
 Since 1.050 kips > 0.845 kips

Resistance to Sliding Checks OK.

CHECK OVERTURNING ANCHOR PULLOUT/UPLIFT RESISTANCE:

Use Load Combination FBC 1605.3.1 Eq. 16-15
 $0.6D + 0.6W$
 On one post
 Pull-up R1 = 2.607 kips
 Max uplift resistance at one post = 2.750 kips
 Since 2.750 kips > 2.607 kips

Anchor Resistance to Overturning Checks OK.

CHECK BRACE RESISTANCE TO MOMENT:

Use worst case on one post
 Moment at brace MB = 16.907 kip-in per post
 Max moment resistance at brace = 21.2 kip-in
 Since 21.2 kip-in > 16.907 kip-in

Moment at Stand Brace Checks OK.

CHECK SHEET METAL ENVELOPE FASTENER RESISTANCE:

Analysis based on AISI S100-2007 "Cold Formed Steel Structural Members" Section E4:Screw Connections
 Use Load Combination FBC 1605.3.1 Eq. 16-15
 $0.6D + 0.6W$
 On long side worst case
 $0.60 \cdot Fw_lat = 0.60 \cdot 5636 \# = 3382 \text{ lbs}$

Resistance to the metal shell pull-off is the minimum of the tensile strength of the screw and the pull-over strength of the sheet metal.

Inputs:

#10 screw, d = 0.19" with integral 0.5"-diameter washer
 Thickness of metal shell, t1 = 0.043" (18 gauge)
 Depth of penetration of screw into frame, tc = 0.25"
 Strength of screw, Fu1 = 55 ksi

Based on the above data:

Allowable tensile of the screw, Pts/Q = 321 lbs per screw (where Q = 3.0)
 Allowable Pull-out strength, Pnot/Q = 170 lbs per screw
 Allowable Pull-over strength, Pnov/Q = 371 lbs per screw
 Therefore the min number of screws per long side = $3382 \# / 170 \#/\text{screw} = 19.89 \text{ screws}$
 Rounds up to min 20 screws per side, use 22 screws for symmetry & spacing.

Anchor Resistance to Metal Enclosure Pull-Off Checks OK.

VERIFY STRENGTH OF SUPPORT BARS AND CONNECTIONS:

Use Load Combination
 $0.67 D + 0.78 W$

Max uplift on one side of AC Unit at mounting anchors:

$F_M1 = (0.78 \cdot Fw_lat \cdot H/2) / (2 \cdot M1) + (0.78 \cdot Fw_vert - 0.67 \cdot Wt) / 4 =$
 $F_M1 = (0.78 \cdot 5.64 \text{ kips} \cdot 66.13 \text{ in} / 2) / (2 \cdot 29.06 \text{ in}) + (0.78 \cdot 1.24 \text{ kips} - 0.67 \cdot 0.442 \text{ kips}) / 4$
 $F_M1 = 2.67 \text{ kips}$
 Allowable tensile capacity of bolt = 4.42 kips > 2.67 kips

Bolt Resistance at Mounting Anchor Checks OK

Max uplift on one side of AC Unit at side support HSS:

$F_STDP = (0.78 \cdot Fw_lat \cdot H/2) / (2 \cdot STDP) + (0.78 \cdot Fw_vert - 0.67 \cdot Wt) / 4 =$
 $F_STDP = (0.78 \cdot 5.64 \text{ kips} \cdot 66.13 \text{ in} / 2) / (2 \cdot 48 \text{ in}) + (0.78 \cdot 1.24 \text{ kips} - 0.67 \cdot 0.442 \text{ kips}) / 4$
 $F_STDP = 1.68 \text{ kips}$
 Allowable tensile capacity of 2 bolts = $2 \cdot 2.49 \text{ kips} = 4.97 \text{ kips} > 1.68 \text{ kips}$

Bolt Resistance at Side Supports Checks OK

Max moment in Support Angle:

$F_M1 \cdot (STDP - M1) / 2 = 2.67 \text{ kips} \cdot (48 \text{ in} - 29.06 \text{ in}) / 2 = 25.23 \text{ kip-in}$
 $Sx \cdot Fy / Q = 1.44 \text{ in}^3 \cdot 36 \text{ ksi} / 1.67 = 31.04 \text{ kip-in} > 25.23 \text{ kip-in}$

Support Angle Flexural Capacity Checks OK

Max moment in Side HSS:

$F_STDP \cdot (STWD - M4) / 2 = 1.68 \text{ kips} \cdot (48 \text{ in} - 31.19 \text{ in}) / 2 = 14.13 \text{ kip-in}$
 $Sy \cdot Fy / Q = 0.932 \text{ in}^3 \cdot 46 \text{ ksi} / 1.67 = 25.67 \text{ kip-in} > 14.13 \text{ kip-in}$

Side HSS Flexural Capacity Checks OK

THE CALCULATIONS ON THE DRAWING ARE REPRESENTATIVE OF THE FOLLOWING LG ELECTRONICS OUTDOOR CONDENSING UNITS:

- ARUB072BTE4
- ARUB072DTE4
- ARUN072BTE4
- ARUN072DTE4
- ARUB072BTE5
- ARUB072DTE5

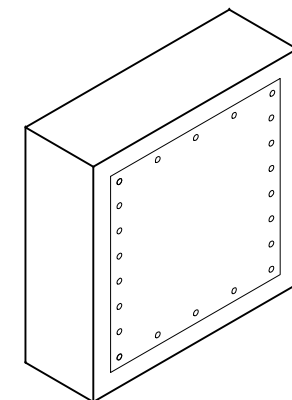

DRAWING TITLE: 36-30-R-109 CALCULATIONS
 PROJECT TITLE: LG ELECTRONICS USA HVAC OUTDOOR CONDENSING UNIT ROOF MOUNT CONFIGURATION

REVISIONS		DATE	DESCRIPTION

SCALE	DATE
NTS	11/02/16
DRAWN BY	PROJECT MGR
JDP	PCP
PROJECT NO.	FLAT FILE
160387	
DRAWING NO.	
36-30-R-109	
SHEET 2 OF 2	

State of Florida
 Certificate of Authorization
 # 31626

