

Job Name : _____
 Purchaser : _____
 Engineer : _____
 Submitted To : _____
 Submitted By : _____
 Unit Designation : Schedule No.: _____

Location : _____
 P.O. No. : _____
 Architect : _____
 Date : _____
 For : Reference Approval Construction
 Model No.: _____

Submittal Data : PTAC & PTHP - 265V



Standard Features :

- Five Year Parts and Labor Warranty on Sealed Refrigerant System
- One Year Full System Warranty on Parts and Labor, 2-5 Year Parts
- R-22 Refrigerant
- Ultra Quiet Operation
- High Energy Efficiency
- Digital Control Display
- Gold Fin™ Anti-corrosion Treatment for Condenser
- Auto Restart
- Energy Saver Mode
- Front Desk Control
- Freeze Room Protection
- Dip Switch setting for temperature limiting
- Temperature Display on unit
- Unit Dimension (inches, WxHxD) : 42 x 16 x 19 7/8

Front Grille Assembly

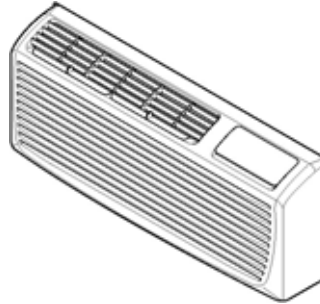

Unit

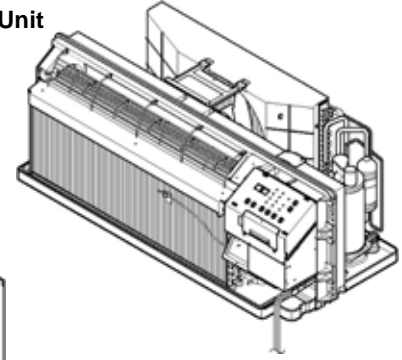

Unit Specification :

Model No.	Cooling Capacity (Btu/h)	EER	Heating Capacity (Btu/h)	COP	Electric Heater (kW)	Power Supply (V,Ph,HZ)	Air Circulation (CFM, H/L)	Dehumidification (pts/hr)	Current (Amps)		Input (Watts)		Maximum Overcurrent Protection (A)	Weight Net/Gross (lbs)
									Cooling	Heating	Cooling	Heating		
LP070CED1	7,600	11.7	-	-	2.0	265,1,60	300/270	2.0	2.6	-	650	-	15	88/92
LP090CED1	8,900	11.0	-	-	3.7	265,1,60	300/270	2.6	3.2	-	810	-	20	87/91
LP120CED1	11,800	10.7	-	-	3.7	265,1,60	420/390	3.3	4.4	-	1,105	-	20	94/98
LP150CED1	14,000	9.5	-	-	3.7	265,1,60	420/390	4.4	5.8	-	1,475	-	20	102/106
LP155CED1	14,000	9.5	-	-	5.0	265,1,60	420/390	4.4	5.8	-	1,475	-	30	102/106
LP070HED1	7,300	11.6	6,200	3.3	2.0	265,1,60	300/270	2.0	2.5	2.2	630	550	15	91/95
LP090HED1	9,300	11.2	8,000	3.4	3.7	265,1,60	300/270	2.6	3.3	2.7	830	690	20	92/96
LP120HED1	12,000	10.4	10,800	3.2	3.7	265,1,60	420/390	3.3	4.6	3.9	1,155	990	20	99/103
LP150HED1	14,400	9.2	13,200	2.9	3.7	265,1,60	420/390	4.4	6.2	5.3	1,565	1,335	20	106/110
LP155HED1	14,400	9.2	13,200	2.9	5.0	265,1,60	420/390	4.4	6.2	5.3	1,565	1,335	30	106/110

Accessories :

Wall Sleeve (42"W*16"H*13 3/4"D)	AYSVB01A	Remote Escutcheon Kit (10 pack)	AYRE110
Stamped Aluminum Grille	AYRGALA01	Wall Thermostat Connection Kit	AYWH101
Architecture Grille - Aluminum	AYAGALA01A	EMS/Front Desk Control Connection Kit	AYFD101
Architecture Grille - Dark Bronze	AYAGALB01A	Condensate Drain Kit	AYDR101
Architecture Grille - Soft Dove	AYAGALC01A	Hard Wire Kit	AYHW101
Leveling Legs	AYLL101	Replacement Filter (10 pack)	AYFT110
Lateral Duct Kit	AYLD1A	Control Panel Key Lock	AYCP101

Wall Thermostats :

Wired Wall Thermostat	PYRCUCA0A
Wireless Wall Thermostat	PYRCUCC0A
Current Tap (for Wireless Wall Thermostat)	PYRCUCC1A
Adaptor Kit of Wireless Thermostat (for GE)	PYADTGE1A
Adaptor Kit of Wireless Thermostat (for Amana)	PYADTAM1A

Note :